

ZAWÓR ZAPOROWY grzybkowy, kołnierzowy		КЛАПАН ЗАПОРНЫЙ, фланцевый	STOP VALVE with disc, with flanged ends
PN6 (0,6 MPa)	DN 15 - 200	prosty Прямой a straight-way form	Fig. 215
PN16 (1,6 MPa)	DN 15 - 300		
PN25 (2,5 MPa)	DN 15 - 200		
PN40 (4,0 MPa)	DN 15 - 200		
PN6 (0,6 MPa)	DN 15 - 200	kątowy Угловой angle form	Fig. 216
PN16 (1,6 MPa)	DN 15 - 300		
PN25 (2,5 MPa)	DN 15 - 80		
PN40 (4,0 MPa)	DN 15 - 200		

ZASTOSOWANIE

Woda przemysłowa zimna i gorąca, para wodna, powietrze, czynniki obojętne.

ZALETY

- wysoki stopień szczelności,
- zwarta zabudowa,
- nie wymaga konserwacji,
- bezpieczny ekologicznie.

ПРИМЕНЕНИЕ

Для холодной и горячей промышленной воды, для пара, для воздуха, для неагрессивных сред

ДОСТОИНСТВА

- высокий уровень плотности закрытия,
- компактная конструкция,
- не требует постоянного ухода,
- безопасен для окружающей среды.

APPLICATION

Industrial cold and hot water, steam, air, neutral fluids.

ADVANTAGES

- high tightness,
- compact construction,
- no maintenance,
- environment-friendly.



ZAWÓR ZAPOROWY КЛАПАН ЗАПОРНЫЙ STOP VALVE	PN6, PN16, PN25
	Fig. 215
	Fig. 216

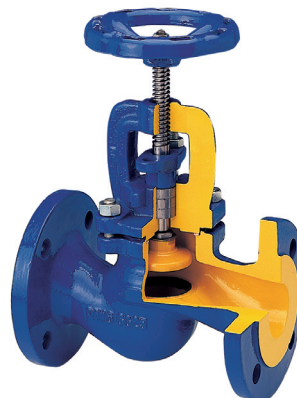

ZAWÓR ZAPOROWO-ZWROTNY КЛАПАН ЗАПОРНЫЙ ОБРАТНЫЙ SCREW-DOWN STOP AND CHECK VALVE	PN6, PN16
	Fig. 215 - (ex. Fig. 330)
	Fig. 216 - (ex. Fig. 331)

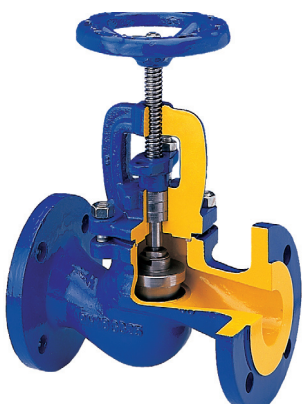

ZAWÓR ZAPOROWY КЛАПАН ЗАПОРНЫЙ STOP VALVE	PN40
	Fig. 215 - (ex. Fig. 218) Fig. 215 - (ex. Fig. 222)
ZAWÓR ZAPOROWO-ZWROTNY КЛАПАН ЗАПОРНЫЙ ОБРАТНЫЙ SCREW-DOWN STOP AND CHECK VALVE	Fig. 215 - (ex. Fig. 468)



ZAWÓR ZAPOROWY Z GRZYBEM DŁAWIĄCYM КЛАПАН ЗАПОРНЫЙ С ДРОССЕЛЬНЫМ КЛАПАНОМ STOP VALVE WITH THROTTLING DISC	PN16, PN25, PN40
	Fig. 215 - (ex. Fig. 225)
	Fig. 216 - (ex. Fig. 226)

A ⇒ EN-GJL-250, C ⇒ EN-GLS-400-18-LT, E ⇒ CuSn10-B, F ⇒ GP240GH

Odmiany, Варианты, Variants		215F	215A, 216A				216C			216E
1.	Kadłub / Корпус / Body	GP240GH 1.0619	EN-GJL-250 JL - 1040				EN-GJS-400-18-LT			CuSn5Zn5Pb-C
2.	Pokrywa / Крышка / Bonnet		DN 15-32 - EN-GJS-500-7 DN 40-300 - EN-GJL-250				JS - 1025			
3.	Dławik / Сальник / Gland									
4.	Grzyb / Клапан / Disc	X20Cr13 1.4021	CuSn10-B		X20Cr13 1.4021	CuSn10B		CuSn5Zn5Pb - C		
5.	Trzpień / Шпindel / Stem		CuZn40Mn2	CuSn10		CuZn40Mn2	CuSn10B		CuZn35Ni	
6.	Pierścień kadłuba / Кольцо корпуса / Seat ring	X12Cr13 1.4006	CuSn10		X12Cr13 1.4006	CuSn10B		CuSn5Zn5Pb-C		
7.	Szczeliwo / Уплотнение / Gland packing	Grafit / Графит / All-graphite								
8.	Uszczelka / Прокладка / Seal	Graphit - CrNiSt								
Max. temperatura pracy Макс. рабочая температура Max. working temperature		400 °C	300 °C	225 °C	225 °C	350 °C	225 °C	225 °C	200 °C	
Uwaga: Materiał wg EN.		Примечание: Материалы поданы по EN.				Note: Material in accordance to EN.				

DN	PN 6				PN 16				PN 6, PN 16		PN 25					PN 6, PN 16, PN 25 Fig. 215			
	Dz	Dp	Do	n x d	Dz	Dp	Do	n x d	g	f	Dz	Dp	Do	n x d	g	L	H	kg	Kv
mm																mm		kg	m³/h
15	80	38	55	4 x 11	95	46	65	4 x 14	14	2	95	46	65	4 x 14	14	130	167	3,3	5,9
20	90	48	65	4 x 11	105	56	75	4 x 14	16	2	105	56	75	4 x 14	16	150	167	3,9	7,4
25	100	58	75	4 x 11	115	65	85	4 x 14	16	2	115	65	85	4 x 14	16	160	175	5,0	13,0
32	120	69	90	4 x 14	140	76	100	4 x 19	18	2	140	76	100	4 x 19	18	180	186	6,6	18,0
40	130	78	100	4 x 14	150	84	110	4 x 19	18	3	150	84	110	4 x 19	19	200	235	8,4	30,0
50	140	88	110	4 x 14	165	99	125	4 x 19	20	3	165	99	125	4 x 19	19	230	248	12,0	41,0
65	160	108	130	4 x 14	185	118	145	4 x 19	20	3	185	118	145	8 x 19	19	290	260	17,3	79,0
80	190	124	150	4 x 19	200	132	160	8 x 19	22	3	200	132	160	8 x 19	19	310	291	22,7	115
100	210	144	170	4 x 19	220	156	180	8 x 19	24	3	235	156	190	8 x 23	19	350	338	35,8	181
125	240	174	200	8 x 19	250	184	210	8 x 19	26	3	270	184	220	8 x 28	19	400	384	52,8	225
150	265	199	225	8 x 19	285	211	240	8 x 23	26	3	300	211	250	8 x 28	20	480	429	74,2	364
200	320	254	280	8 x 19	340	266	295	12 x 23	30	3	360	274	310	12 x 28	22	600	529	126	690
250	-	-	-	-	405	319	355	12 x 28	32	3	-	-	-	-	-	730	638	200	1010
300	-	-	-	-	460	370	410	12 x 28	32	4	-	-	-	-	-	850	710	315	1460

DN	PN 6, PN 16, PN 25 Fig. 216				PN40 Fig. 215F								PN16 Fig. 215E									
	L	H	kg	Kv	Dz	Dp	Do	g	f	nx d	H	kg	L	H	D	d	Φk x n x Φd _i	Skok grzyba / Hub / Stroke	kg			
mm	mm		kg	m³/h	mm								mm	kg	mm							
15	90	163	3,1	7,2	95	47	65	16	2	4x14	189	4,0	130	180	95	100	65 x 4 x 14	6	5,0			
20	95	160	3,5	9,2	105	58	75	18	2	4x14	189	5,3	150	200	105	100	75 x 4 x 14	7	5,5			
25	100	173	4,8	16,0	115	68	85	18	2	4x14	189	5,7	160	310	115	100	85 x 4 x 14	8	6,0			
32	105	173	6,6	22,0	140	78	100	18	2	4x18	220	10,0	180	220	140	125	100 x 4 x 18	10	8,0			
40	115	214	8,7	37,0	150	88	110	18	3	4x18	220	13,3	200	250	150	160	110 x 4 x 18	12	10			
50	125	211	11,8	51,0	165	102	125	20	3	4x18	295	15,3	230	250	165	160	125 x 4 x 18	15	12			
65	145	236	14,0	98,5	185	122	145	22	3	8x18	295	25,2	290	315	185	200	145 x 4 x 18	19	17			
80	155	250	20,5	143	200	133	160	24	3	8x18	368	32,2	310	335	200	200	160 x 4 x 18	24	23			
100	175	301	32,2	226	235	162	190	24	3	8x22	368	50,5	350	375	220	250	180 x 4 x 18	28	30			
125	200	339	46,0	281	270	184	220	26	3	8x26	523	78,0	400	420	250	250	210 x 4 x 18	36	50			
150	225	383	62,0	455	300	218	250	28	3	8x26	523	104,0	480	460	285	315	240 x 4 x 22	40	65			
200	275	455	106	860	375	280	320	34	3	12x30	680	198,0	600	550	340	400	295 x 4 x 22	56	110			
250	325	531	-	1260	-	-	-	-	-	-	-	-	730	670	395	400	350 x 4 x 22	65	165			
300	375	710	-	-	-	-	-	-	-	-	-	-	850	750	445	400	400 x 4 x 22	80	295			

ZAWÓR ZAPOROWY / КЛАПАН ЗАПОРНЫЙ / STOP VALVE

Skok grzyba / Ход клапана / Stroke		
DN	h	
mm		
15	5	7
20	5,5	10
25	7	13
32	14	14
40	20	17
50	25	17
65	35	30
80	41	32
100	31	38
125	48	63
150	54	63
200	77	
250	120	
300	120	
	PN6, PN16	PN40

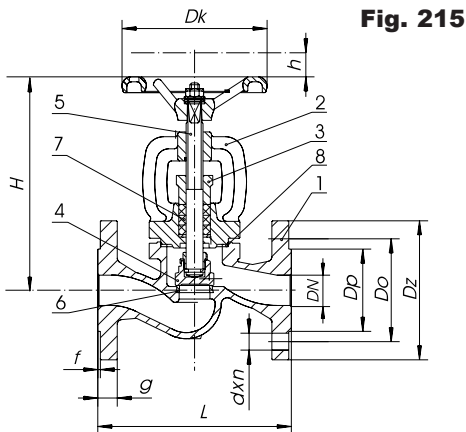

Fig. 215

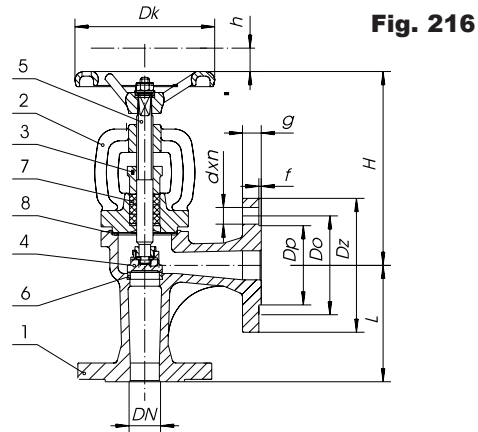

Fig. 216

PN =>	PN40	PN6, PN16, PN25		00	01, 02, 03
OPCJA / ВАРИАНТ / OPTIONAL =>	00, 01	00, 01	02	03	
Grzyb / Клапан / Plug	X20Cr13 1.4021	X20Cr13 1.4021	CuSn10		
Trzpień / Шпindelъ / Stem	X20Cr13 1.4021	X20Cr13 1.4021	CuZn40Mn2	CuSn10-B	
Pierścień kadłuba / Кольцо корпуса / Seat ring	X12Cr13 1.4006	X12Cr13 1.4006	CuSn10		

ZAWÓR ZAPOROWO - ZWROTNY / КЛАПАН ЗАПОРНЫЙ ОБРАТНЫЙ / SCREW - DOWN STOP AND CHECK VALVE

Skok grzyba / Ход клапана / Stroke		
DN	h	
mm		
15	5	4
20	5	5
25	8	6
32	9	8
40	12	10
50	13	13
65	16	17
80	20	20
100	25	25
125	32	32
150	38	38
200	50	50
250	62	
300	100	
	PN6, PN16	PN40

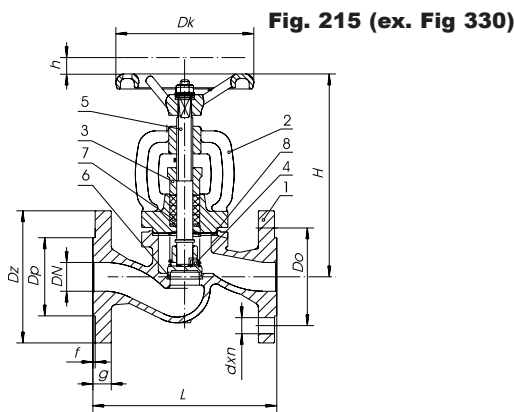

Fig. 215 (ex. Fig 330)

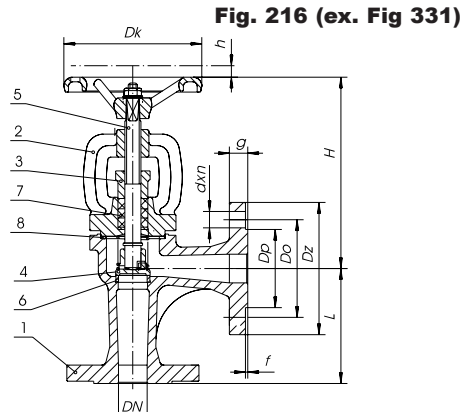

Fig. 216 (ex. Fig 331)

PN =>	PN40	PN6, PN16, PN25		Sprężyna / Пружина / Spring	41, 42, 43
OPCJA / ВАРИАНТ / OPTIONAL =>	31	31, 41	32, 42	33, 43	
Grzyb / Клапан / Plug	X20Cr13 1.4021	X20Cr13 1.4021	CuSn10		
Trzpień / Шпindelъ / Stem	X20Cr13 1.4021	X20Cr13 1.4021	CuZn40Mn2	CuSn10-B	
Pierścień kadłuba / Кольцо корпуса / Seat ring	X12Cr13 1.4006	X12Cr13 1.4006	CuSn10		
			X17CrNi16-2 1.4057		

ZAWÓR ZAPOROWY Z GRZYBEM DŁAWIĄCYM / КЛАПАН ЗАПОРНЫЙ С ДРОСЕЛЬНЫМ КЛАПАНОМ / STOP VALVE WITH THROTTLING DISC

DN	H	H ₁	KV _s	
mm			kg	[m ³ /h]
15	190	173	3,0	4,7
20	190	173	3,9	4,5
25	205	180	5,0	9,1
32	221	188	6,5	13,0
40	249	231	9,5	20,0
50	262	238	12,5	30,0
65	298	265	17,6	60,0
80	335	295	24,0	90,0
100	377	342	36,8	125
125	427	382	52,6	200
150	476	426	76,5	270
200	570	526	108,5	550
250	675	638	200,0	950
300	735	710	-	-

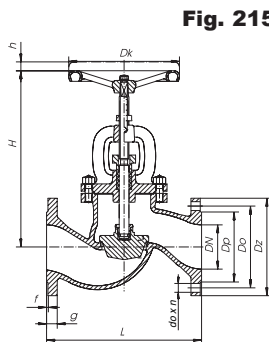

Fig. 215.91

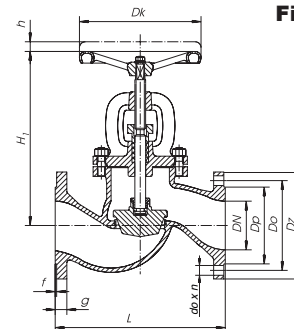
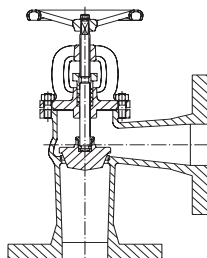

Fig. 215.71

Zawór ze wskaźnikiem / Клапан с указателем открытия / Valve with indicator

Zawór ze wskaźnikiem / Клапан с указателем открытия / Valve with indicator

PN =>	PN16, PN25, PN 40			
OPCJA / ВАРИАНТ / OPTIONAL =>	91,71			
Grzyb / Клапан / Plug	X20Cr13 1.4021			
Trzpień / Шпindelъ / Stem	X20Cr13 1.4021			
Pierścień kadłuba / Кольцо корпуса / Seat ring	X12Cr13 1.4006			
Dopuszczalna różnica ciśnień / Допустимая разница давления / Differential pressure	DN	200 mm	250 mm	300 mm
	Δp	1,0 MPa	0,6 MPa	0,4 MPa

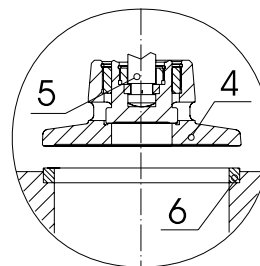

**Fig. 216 DN 15 - 300, PN16
Fig. 216 DN 15 - 80, PN25**

Na życzenie klienta
По желанию клиента
On customer's request

PN40	
DN[mm]	Δp max [bar]
15 - 100	40
125	33
150	21
200	14

DN 200 - 300 → Fig. 215A, Fig. 216A
 DN 125 - 200 → Fig. 215F



215.04

Na życzenie klienta / По желанию клиента / On customers request

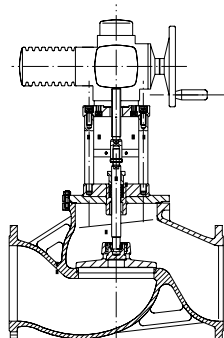
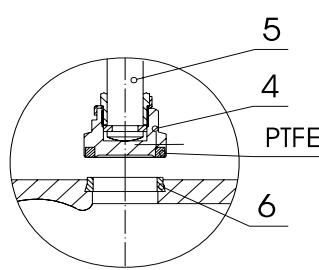
Przy specjalnym zamówieniu, na życzenie klienta При специальном заказе по желанию клиента Special orders on customer's request	DN 15 - 80	Fig. 215.08, Fig. 216.08 DN 15 - 150
 <p>Napęd armatury Elektromechaniczny: ZPA NOVA PAKA, typ ZEPADYN</p> <p>Привод к клапану Электромеханический: ZPA NOVA PAKA, typ ZEPADYN</p> <p>Valve actuator Electromechanical actuator: ZPA NOVA PAKA, typ ZEPADYN</p>	<p>Max. temperatura pracy Макс. рабочая температура Max. working temperature</p> <p style="text-align: right;">200°C</p> 	

Kolnierze Фланцы Flanges	PN6, PN16 → EN 1092 - 2
--------------------------------	-------------------------

Długość zabudowy Длина застройки Face to face length	EN 558-1 → 1-Fig. 215, 8 - Fig. 216 (DIN3202 → F1-Fig.215, F32 - Fig. 216)
--	---

EN 1092-2: 1997									
Ciśnienie - temperatura Давление-Температура Pressure - temperature									
EN-GJL-250				EN-GJS-400-18-LT				GP240GH (1.0619)	
PN6		PN16		PN16		PN25		PN40	
°C	bar	°C	bar	°C	bar	°C	bar	°C	bar
-10	6	-10	16	-10	16	-10	25	-50	-
120	6	120	16	120	16	120	25	-20	40
150	5,4	150	14,4	150	15,5	150	24,3	120	40
180	5	180	13,4	200	14,7	200	23	200	35
200	4,4	200	12,8	250	13,9	250	21,8	250	32
230	4,4	230	11,8	300	12,8	300	20	300	28
250	4,2	250	11,2	350	11,2	350	17,5	350	24
300	3,6	300	9,6	-	-	-	-	400	21

PRZYKŁAD ZAMÓWIENIA
ПРИМЕР ЗАКАЗА
ORDER EXAMPLE

215A025C01

Figura/Фигура /Figure	215
Material kadłuba/Материал корпуса /Body material	A
Średnica nominalna/Номинальный диаметр /Nominal diameter	025
Ciśnienie nominalne/Номинальное давление /Nominal pressure	C
Wykonanie/Исполнение/Type	01

Informacje mają charakter ogólny.
Szczegółowych informacji udziela dział Marketingu.

Fig 215F, 216F - Armatura komplementarna

Sekretariat tel. (0048) (074) 867 28 48
865 21 00
fax (0048) (074) 865 21 01
e-mail: zetkama@zetkama.com.pl

Информация носит общий характер. Более детальную
информацию представляет отдел Маркетинга

Фиг.215F, 216F – производится в кооперации

Спрzedaż krajowa tel. (0048) (074) 865 21 52
865 21 88
fax (0048) (074) 865 21 98
e-mail: spkraj@zetkama.com.pl

These data are for information only. Our marketing department provides you with detailed specifications.

Fig 215F, 216F - Cooperation valves

Marketing tel. (0048) (074) 865 21 74
fax (0048) (074) 865 21 98
e-mail: marketing@zetkama.com.pl